



OPERATOR'S AND PARTS MANUAL

4-IN-1 MULTI-PURPOSE CONSTRUCTION BUCKETS



PALADIN LIGHT CONSTRUCTION



SERIAL NUMBER: _____

MODEL NUMBER: _____

Manual Number: OM715
Part Number: 75615
Rev.

TABLE OF CONTENTS

PREFACE	3
SAFETY PRECAUTIONS	
SAFETY STATEMENTS	5
GENERAL SAFETY PRECAUTIONS	5-7
EQUIPMENT SAFETY PRECAUTIONS	8
DECALS	
DECAL PLACEMENT	9
DECALS	10
INSTALLATION AND OPERATION	11-12
MAINTENANCE AND SERVICE	
LUBRICATION	13
CYLINDER SEAL REPLACEMENT	14-15
SPECIFICATIONS	
ATTACHMENT SPECIFICATIONS	16
BOLT TORQUE SPECIFICATIONS	17
LIMITED WARRANTY	19
PARTS	
4-IN-1 MULTI-PURPOSE BUCKET ASSEMBLY	20-21
HYDRAULIC ASSEMBLIES	22-23
CYLINDER ASSEMBLY	24-25
OPTIONS	26-27

PREFACE

GENERAL COMMENTS

Congratulations on the purchase of your new BRADCO product! This product was carefully designed and manufactured to give you many years of dependable service. Only minor maintenance (such as cleaning and lubricating) is required to keep it in top working condition. Be sure to observe all maintenance procedures and safety precautions in this manual and on any safety decals located on the product and on any equipment on which the attachment is mounted.

This manual has been designed to help you do a better, safer job. Read this manual carefully and become familiar with its contents.

WARNING!  **Never let anyone operate this unit without reading the "Safety Precautions" and "Operating Instructions" sections of this manual. Always choose hard, level ground to park the vehicle on and set the brake so the unit cannot roll.**

Unless noted otherwise, right and left sides are determined from the operator's control position when facing the attachment.

NOTE: The illustrations and data used in this manual were current (according to the information available to us) at the time of printing, however, we reserve the right to redesign and change the attachment as may be necessary without notification.

BEFORE OPERATION

The primary responsibility for safety with this equipment falls to the operator. Make sure the equipment is operated only by trained individuals that have read and understand this manual. If there is any portion of this manual or function you do not understand, contact your local authorized dealer or the manufacturer.

SAFETY ALERT SYMBOL



This is the "Safety Alert Symbol" used by this industry. This symbol is used to warn of possible injury. Be sure to read all warnings carefully. They are included for your safety and for the safety of others working with you.

SERVICE

When servicing your product, remember to use only manufacturer replacement parts. Substitute parts may not meet the standards required for safe, dependable operation.

To facilitate parts ordering, record the model and serial number of your unit in the space provided on the cover of this manual. This information may be obtained from the identification plate located on the product.

The parts department needs this information to insure that you receive the correct parts for your specific model.

SAFETY STATEMENTS



THIS SYMBOL BY ITSELF OR WITH A WARNING WORD THROUGHOUT THIS MANUAL IS USED TO CALL YOUR ATTENTION TO INSTRUCTIONS INVOLVING YOUR PERSONAL SAFETY OR THE SAFETY OF OTHERS. FAILURE TO FOLLOW THESE INSTRUCTIONS CAN RESULT IN INJURY OR DEATH.



DANGER

THIS SIGNAL WORD IS USED WHERE SERIOUS INJURY OR DEATH WILL RESULT IF THE INSTRUCTIONS ARE NOT FOLLOWED PROPERLY.



WARNING

THIS SIGNAL WORD IS USED WHERE SERIOUS INJURY OR DEATH COULD RESULT IF THE INSTRUCTIONS ARE NOT FOLLOWED PROPERLY.



CAUTION

THIS SIGNAL WORD IS USED WHERE MINOR INJURY COULD RESULT IF THE INSTRUCTIONS ARE NOT FOLLOWED PROPERLY.

NOTICE

NOTICE INDICATES A PROPERTY DAMAGE MESSAGE.

GENERAL SAFETY PRECAUTIONS

WARNING!

READ MANUAL PRIOR TO INSTALLATION



Improper installation, operation, or maintenance of this equipment could result in serious injury or death. Operators and maintenance personnel should read this manual, as well as all manuals related to this equipment and the prime mover thoroughly before beginning installation, operation, or maintenance. **FOLLOW ALL SAFETY INSTRUCTIONS IN THIS MANUAL AND THE PRIME MOVER'S MANUAL(S).**



READ AND UNDERSTAND ALL SAFETY STATEMENTS

Read all safety decals and safety statements in all manuals prior to operating or working on this equipment. Know and obey all OSHA regulations, local laws, and other professional guidelines for your operation. Know and follow good work practices when assembling, maintaining, repairing, mounting, removing, or operating this equipment.



KNOW YOUR EQUIPMENT

Know your equipment's capabilities, dimensions, and operations before operating. Visually inspect your equipment before you start, and never operate equipment that is not in proper working order with all safety devices intact. Check all hardware to ensure it is tight. Make certain that all locking pins, latches, and connection devices are properly installed and secured. Remove and replace any damaged, fatigued, or excessively worn parts. Make certain all safety decals are in place and are legible. Keep decals clean, and replace them if they become worn or hard to read.

GENERAL SAFETY PRECAUTIONS

WARNING!



PROTECT AGAINST FLYING DEBRIS

Always wear proper safety glasses, goggles, or a face shield when driving pins in or out, or when any operation causes dust, flying debris, or any other hazardous material.

WARNING!



LOWER OR SUPPORT RAISED EQUIPMENT

Do not work under raised booms without supporting them. Do not use support material made of concrete blocks, logs, buckets, barrels, or any other material that could suddenly collapse or shift positions. Make sure support material is solid, not decayed, warped, twisted, or tapered. Lower booms to ground level or on blocks. Lower booms and attachments to the ground before leaving the cab or operator's station.

WARNING!



USE CARE WITH HYDRAULIC FLUID PRESSURE

Hydraulic fluid under pressure can penetrate the skin and cause serious injury or death. Hydraulic leaks under pressure may not be visible. Before connecting or disconnecting hydraulic hoses, read your prime mover's operator's manual for detailed instructions on connecting and disconnecting hydraulic hoses or fittings.

- Keep unprotected body parts, such as face, eyes, and arms as far away as possible from a suspected leak. Flesh injected with hydraulic fluid may develop gangrene or other permanent disabilities.
- If injured by injected fluid, see a doctor at once. If your doctor is not familiar with this type of injury, ask him to research it immediately to determine proper treatment.
- Wear safety glasses, protective clothing, and use a piece of cardboard or wood when searching for hydraulic leaks. **DO NOT USE YOUR HANDS!** **SEE ILLUSTRATION.**

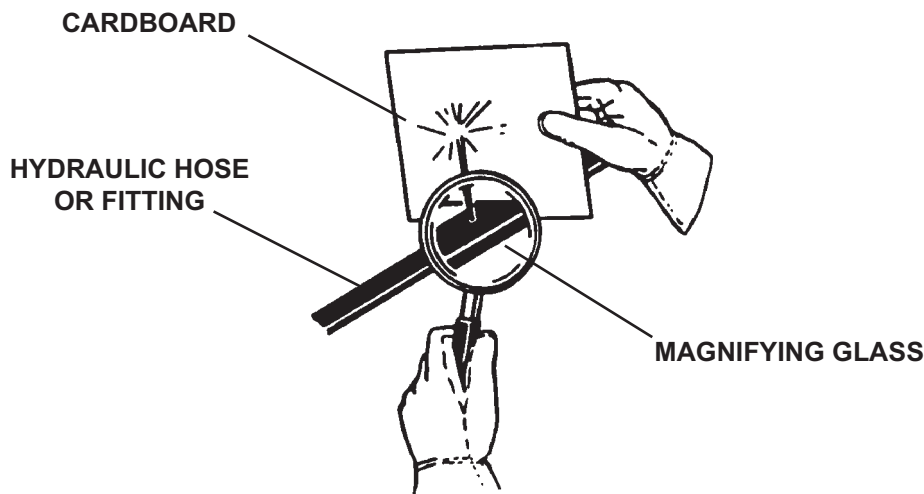

GENERAL SAFETY PRECAUTIONS

WARNING!



DO NOT MODIFY MACHINE OR ATTACHMENTS

Modifications may weaken the integrity of the attachment and may impair the function, safety, life, and performance of the attachment. When making repairs, use only the manufacturer's genuine parts, following authorized instructions. Other parts may be substandard in fit and quality. Never modify any ROPS (Roll Over Protection Structure) or FOPS (Falling Object Protective Structure) equipment or device. Any modifications must be authorized in writing by the manufacturer.

WARNING!



SAFELY MAINTAIN AND REPAIR EQUIPMENT

- Do not wear loose clothing or any accessories that can catch in moving parts. If you have long hair, cover or secure it so that it does not become entangled in the equipment.
- Work on a level surface in a well-lit area.
- Use properly grounded electrical outlets and tools.
- Use the correct tools for the job at hand. Make sure they are in good condition for the task required.
- Wear the protective equipment specified by the tool manufacturer.



SAFELY OPERATE EQUIPMENT

Do not operate equipment until you are completely trained by a qualified operator in how to use the controls, know its capabilities, dimensions, and all safety requirements. See your machine's manual for these instructions.

- Keep all step plates, grab bars, pedals, and controls free of dirt, grease, debris, and oil.
- Never allow anyone to be around the equipment when it is operating.
- Do not allow riders on the attachment or the prime mover.
- Do not operate the equipment from anywhere other than the correct operator's position.
- Never leave equipment unattended with the engine running, or with this attachment in a raised position.
- Do not alter or remove any safety feature from the prime mover or this attachment.
- Know your work site safety rules as well as traffic rules and flow. When in doubt on any safety issue, contact your supervisor or safety coordinator for an explanation.

EQUIPMENT SAFETY PRECAUTIONS

WARNING!



KNOW WHERE UTILITIES ARE

Observe overhead electrical and other utility lines. Be sure equipment will clear them. When digging, call your local utilities for location of buried utility lines, gas, water, and sewer, as well as any other hazard you may encounter.



OPERATING THE 4-IN-1 MULTI-PURPOSE BUCKET

- Do not exceed the lifting capacity of your prime mover.
- Operate only from the operator's station.
- When operating on slopes, drive up and down, not across. Avoid steep hillside operation, which could cause the prime mover to overturn.
- Reduce speed when driving over rough terrain, on a slope, or turning, to avoid overturning the vehicle.
- An operator must not use drugs or alcohol, which can change his or her alertness or coordination. An operator taking prescription or over-the-counter drugs should seek medical advice on whether or not he or she can safely operate equipment.
- Before exiting the prime mover, lower the attachment to the ground, turn off the prime mover's engine, remove the key and apply the brakes.
- Never heap load heavy material where the combined weight of the bucket and material could exceed the rated lifting capacity of the loader.
- Be sure the load does not stick out too far in front of the bucket. A light load sticking out too far can have the same tipping effect as a heavy load carried in close.
- When using the clam, lift the load slightly and make sure that the load is secure. If the load appears to be unstable, lower the load, open the clam and reposition the load to attain full stability.



TRANSPORTING THE 4-IN-1 MULTI-PURPOSE BUCKET

- Travel only with the attachment in a safe transport position to prevent uncontrolled movement. Drive slowly over rough ground and on slopes.
- When driving on public roads use safety lights, reflectors, Slow Moving Vehicle signs etc., to prevent accidents. Check local government regulations that may affect you.
- Do not drive close to ditches, excavations, etc., cave in could result.
- Do not smoke when refueling the prime mover. Allow room in the gas tank for expansion. Wipe up any spilled fuel. Secure cap tightly when done.



MAINTAINING THE 4-IN-1 MULTI-PURPOSE BUCKET

- Before performing maintenance, lower the attachment to the ground, turn off the engine, remove the key and apply the brakes.
- Never perform any work on the attachment unless you are authorized and qualified to do so. Always read the operator service manual's before any repair is made. After completing maintenance or repair, check for correct functioning of the attachment. If not functioning properly, always tag "DO NOT OPERATE" until all problems are corrected.
- Worn, damaged, or illegible safety decals must be replaced. New safety decals can be ordered from BRADCO.
- Never make hydraulic repairs while the system is under pressure. Serious personal injury or death could result.
- Never work under a raised attachment.

10915 3-30-07

DECALS

DECAL PLACEMENT

GENERAL INFORMATION

The diagrams on this page shows the location of the decals used on the BRADCO 4-IN-1 multi-purpose construction buckets. The decals are identified by their part numbers, with reductions of the actual decals located on the following page. Use this information to order replacements for lost or damaged decals. Be sure to read all decals before operating the attachment. They contain information you need to know for both safety and product longevity.

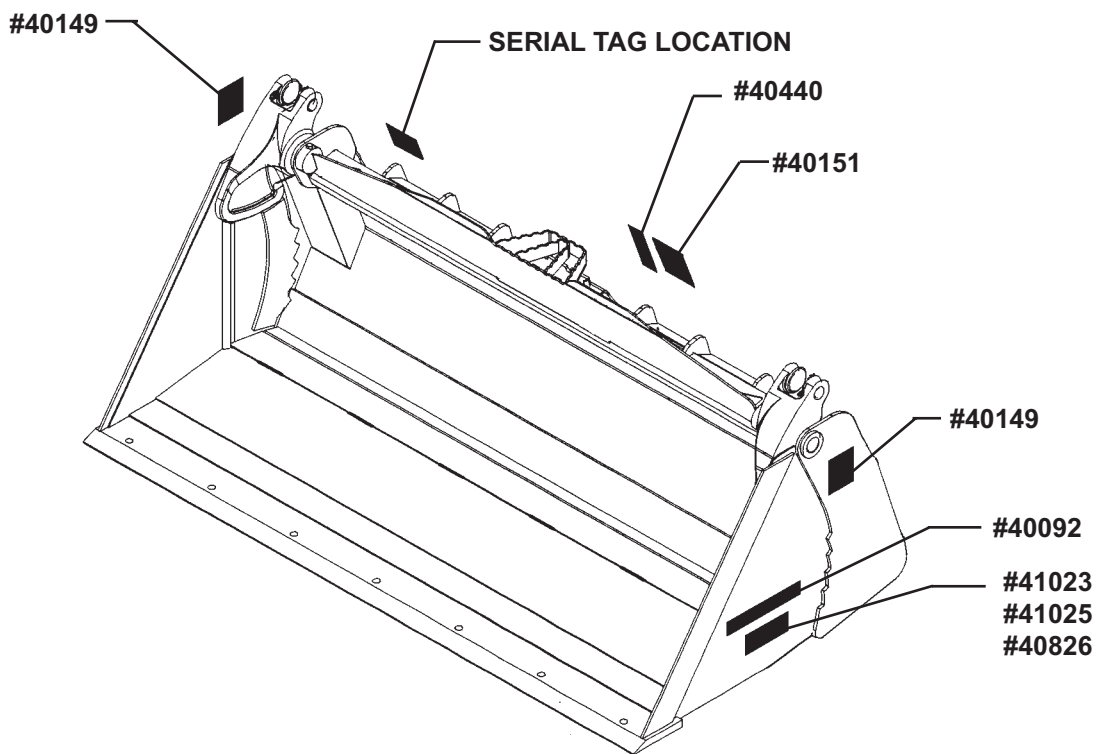

IMPORTANT: Keep all safety signs clean and legible. Replace all missing, illegible, or damaged safety signs. When replacing parts with safety signs attached, the safety signs must also be replaced.

REPLACING SAFETY SIGNS: Clean the area of application with nonflammable solvent, then wash the same area with soap and water. Allow the surface to fully dry. Remove the backing from the safety sign, exposing the adhesive surface. Apply the safety sign to the position shown in the diagram above and smooth out any bubbles.

DECALS



PART #40092
BRADCO LOGO - WHITE



PART #40440
WARNING! CALL BEFORE YOU DIG

MP72

PART #41023
MP66 MODEL NUMBER

MP78

PART #41025
MP72 MODEL NUMBER

MP84

PART #40826
MP72 MODEL NUMBER



PART #40149
DANGER! PINCH POINT



PART #40151
WARNING! HIGH PRESSURE FLUID

INSTALLATION AND OPERATION

INSTALLATION

Your 4-IN-1 bucket was shipped complete with the appropriate mounting for your specific unit, and with the hydraulic hoses and couplers installed.

Install the bucket by following your power unit operator's manual for installing an attachment.

WARNING! To Avoid Serious Personal Injury, make sure the bucket is securely latched to the attachment mechanism of your unit. Failure to do so could result in separation of the bucket from the unit.



Connect the hydraulic quick couplers to the auxiliary hydraulics and route the hoses in such a fashion as to prevent chafing and pinching.

Start engine and slowly cycle the bucket cylinders several times to purge system of air, and check for proper hydraulic connection, hose routing, and hose length.

Check the attachment for proper assembly, installation, and hydraulic leaks.

DETACHING

On firm level ground, close the clam and lower the boom arms completely down on the frame until the bucket is level and approximately 2" off the ground.

Turn off the engine. Move the control levers back and forth to relieve pressure in line. Disconnect couplers.

NOTE: Connect couplers together or install caps to prevent contaminants from entering the hydraulic system.

Follow your power unit operator's manual for detaching (removing) an attachment.

NOTE: Frequent lubrication of grease fittings at the end of the cylinders and pivot points with a multi-purpose grease will greatly increase life of the product.

STORAGE

1. Clean the unit thoroughly, removing all mud, dirt, and grease.
2. Inspect for visible signs of wear, breakage, or damage. Order any parts required and make the necessary repairs to avoid delays when starting next season.
3. Tighten loose nuts, capscrews, and hydraulic connections.
4. Cap hydraulic couplers to protect against contaminants.
5. Touch up all unpainted surfaces with paint, to prevent rust.
6. Coat the exposed portions of the cylinder rods with grease.
7. Store the unit in a dry and protected place. Leaving the unit outside will materially shorten its life.

4-IN-1 MULTI-PURPOSE BUCKET APPLICATIONS

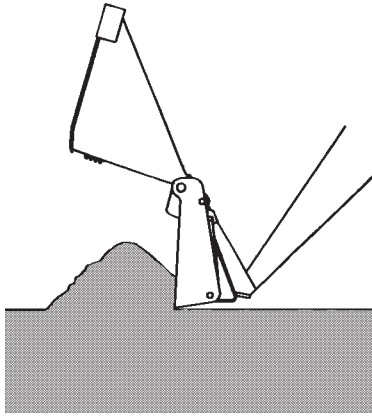

BULLDOZING

For all industry uses: road maintenance, clean up, grading, etc.

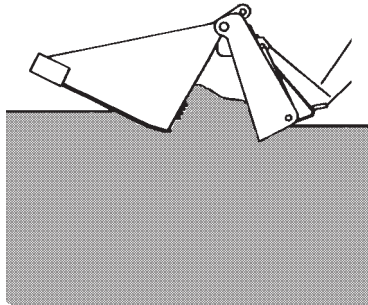

CLAM

Handles the hard to pick up material with ease. Complete control of loading.

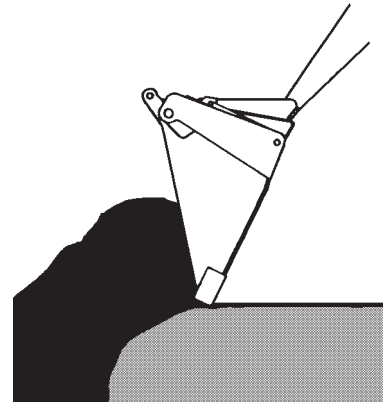

BACKFILLING

Backfilling is no problem.

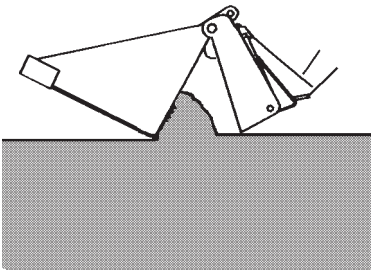

BACKDRAG

For working in close quarters such as between buildings and among trees.

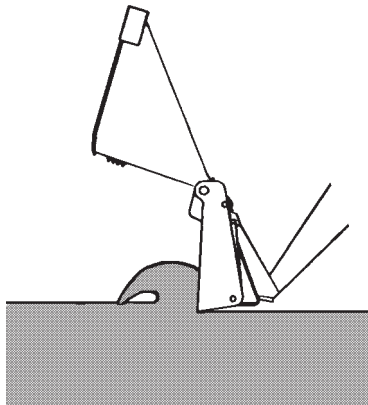

SCRAPING

Cleaning yards, leveling lawns: a landscaper's bucket.

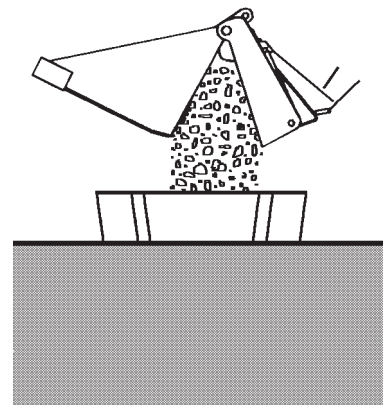

BOTTOM DUMPING

Ideal for trench filling or dumping into a container.

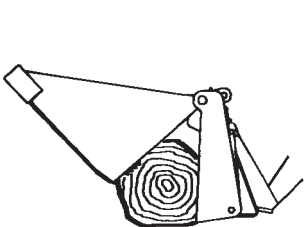

GRAB

Handles all undesirable loading: brush, timbers and all bulky materials.

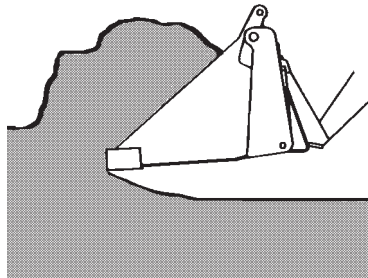

DIGGING

Same as all conventional buckets.

MAINTENANCE & SERVICE

GENERAL INFORMATION

Regular maintenance is the key to long equipment life and safe operation. Maintenance requirements have been reduced to the absolute minimum. However, it is very important that these maintenance functions be performed as described below.

DAILY

- Check all bolts and nuts for tightness.
- Replace any missing bolts or nuts with approved replacement parts.
- Check hydraulic system for hydraulic oil leaks. See procedure below.
- Visually inspect the machine for worn parts or cracked welds, and repair as necessary.

EVERY 40 HOURS

- Lubricate all grease fittings.

WARNING! Escaping fluid under pressure can have sufficient force to penetrate the skin, causing serious personal injury. Fluid escaping from a very small hole can be almost invisible. Use a piece of cardboard or wood, rather than hands, to search for suspected leaks.



Keep unprotected body parts, such as face, eyes, and arms as far away as possible from a suspected leak. Flesh injected with hydraulic fluid may develop gangrene or other permanent disabilities.

If injured by injected fluid, see a doctor at once. If your doctor is not familiar with this type of injury, ask him to research it immediately to determine proper treatment.

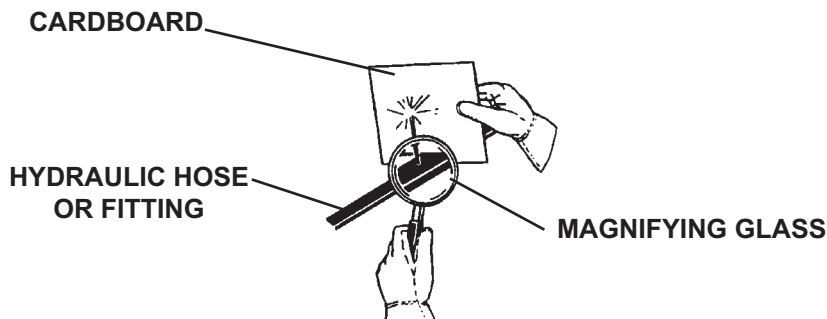

IMPORTANT: When replacing parts, use only factory approved replacement parts. Manufacturer will not claim responsibility for use of unapproved parts or accessories, and/or other damages as a result of their use.

MAINTENANCE AND SERVICE

CYLINDER SEAL REPLACEMENT

The following information is provided to assist you in the event you should need to repair or rebuild a hydraulic cylinder. When working on hydraulic cylinders, make sure that the work area and tools are clean and free of dirt to prevent contamination of the hydraulic system and damage to the hydraulic cylinders. Always protect the active part of the cylinder rod (the chrome section). Nicks or scratches on the surface of the rod could result in cylinder failure. Clean all parts thoroughly with a cleaning solvent before reassembly.

DISASSEMBLY PROCEDURE

IMPORTANT: Do not contact the active surface of the cylinder rod with the vise. Damage to the rod could result.

THREADED TYPE GLAND

1. Rotate the gland with a spanner wrench counterclockwise until the gland is free of the cylinder tube.
2. Pull the cylinder rod from the cylinder tube and inspect the piston and the bore of the cylinder tube for deep scratches or galling. If damaged, the piston AND the cylinder tube must be replaced.

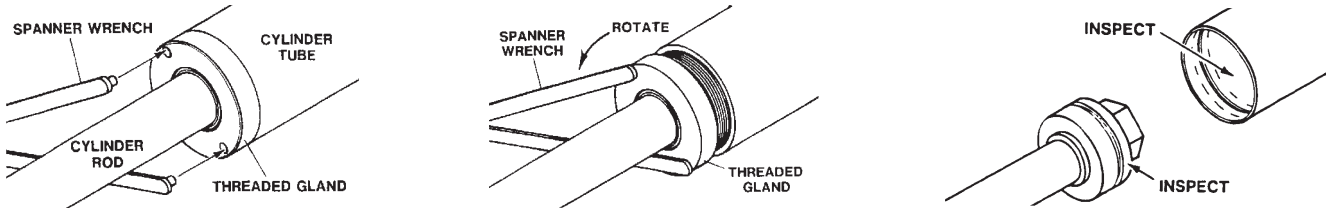

3. Remove the hex nut, piston, flat washer or spacer tube (if so equipped), and gland from the cylinder rod. If the cylinder rod is rusty, scratched, or bent, it must be replaced.
4. Remove and discard all the old seals.



ASSEMBLY PROCEDURE

IMPORTANT: Replace all seals even if they do not appear to be damaged. Failure to replace all seals may result in premature cylinder failure. **NOTE:** Seal kits will service most cylinders of similar bore size and rod diameter.

1. Install the cylinder rod seal in the gland first. Be careful not to damage the seal in the process, as it is somewhat difficult to install.

NOTE: A special installation tool (Part #65349) is available to help with installing the seal. Simply fit the end of the tool over the seal so that the large prong of the tool is on the outside of the seal, and the two smaller prongs on the inside. The lip of the seal should be facing towards the tool. Rotate the handles on the tool around to wrap the seal around the end of the tool.

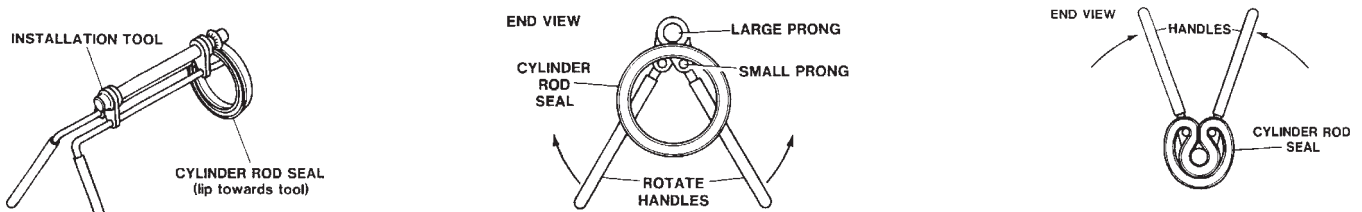

10356 10-13-05

MAINTENANCE AND SERVICE

Now insert the seal into the gland from the inner end. Position the seal in its groove, and release and remove the tool. Press the seal into its seat the rest of the way by hand.

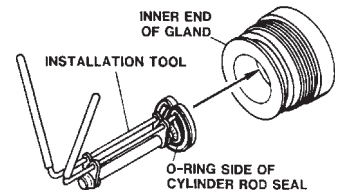

- Install the new piston ring, rod wiper, O-rings and backup washers, if applicable, on the piston.

Be careful not to damage the seals. Caution must be used when installing the piston ring. The ring must be stretched carefully over the piston with a smooth, round, pointed tool.

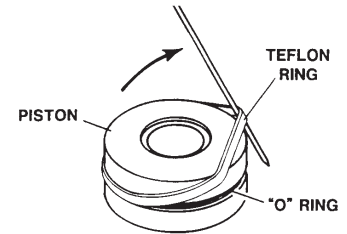

- After installing the rod seal inside the gland, as shown in step #1, install the external seal.

NOTE: Threaded glands may have been equipped with a separate O-ring and backup washer system or a polypak (all in one) type seal. Current seal kits contain a polypak (all in one) type seal to replace the discarded seal types on ALL THREADED GLANDS.

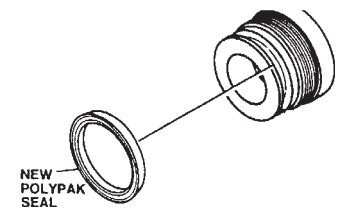

- Slide the gland onto the cylinder rod, being careful not to damage the rod wiper. Then install the spacer, or flat washer (if so equipped), small o-ring, piston, and hex nut onto the end of the cylinder rod.
- Secure the cylinder rod (mounting end) in a vise with a support at its center. Torque the nut to the amount shown for the thread diameter of the cylinder rod (see chart).

Thread Diameter	POUNDS - FEET
7/8"	150-200
*1"	230-325
1-1/8"	350-480
1-1/4"	490-670
1-3/8"	670-900
* 1" Thread Diameter WITH 1.25" Rod Diameter Min. 230 ft. lbs. Max. 250 ft. lbs.	

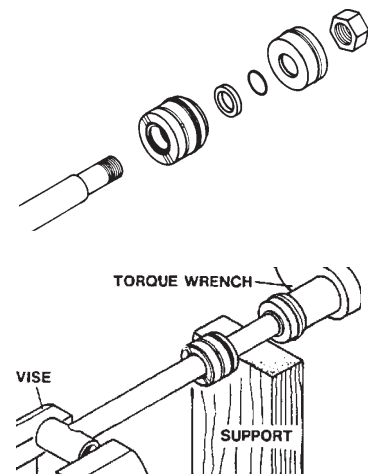

IMPORTANT: Do not contact the active surface of the cylinder rod with the vise. Damage to the rod could result.

- Apply a lubricant (such as Lubriplate #105) to the piston and teflon ring. Insert the cylinder rod assembly into the cylinder tube.

IMPORTANT: Ensure that the piston ring fits squarely into the cylinder tube and piston groove, otherwise the ring may be damaged and a leak will occur.

- Use a spanner wrench to rotate the gland clockwise into the cylinder. Continue to rotate the gland with the spanner wrench until it is tight.

WARNING! Cylinders serviced in the field are to be tested for leakage prior to the attachment being placed in work. Failure to test rebuilt cylinders could result in damage to the cylinder and/or the attachment, cause severe personal injury or even death.



SPECIFICATIONS

4-IN-1 MULTI-PURPOSE CONSTRUCTION BUCKETS

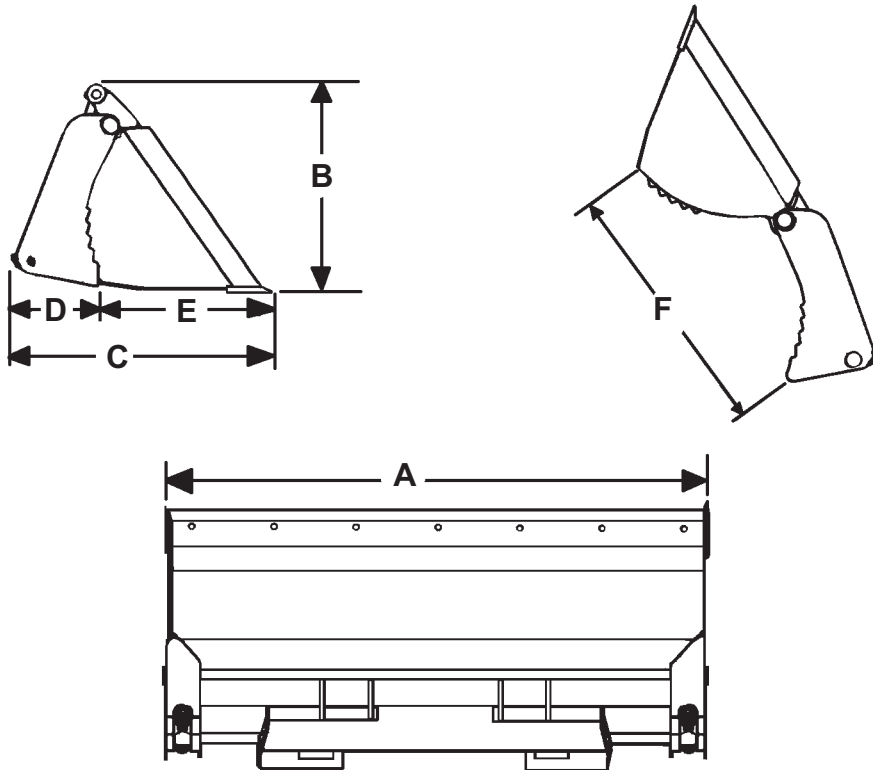

DESCRIPTION	72"	78"	84"
A. Overall Width.....	72.75"	78.75"	84.75"
B. Overall Height.....	27.57"	27.57"	27.57"
C. Overall Length.....	38.13"	38.13"	38.13"
D. Clam Length.....	26.67"	26.67"	27.67"
E. Backblade Length.....	12.41"	12.41"	12.41"
F. Clam Opening.....	34.79"	34.79"	34.79"
Operating Pressure (PSI).....	2250	2250	2250
Clamping Force.....	4011#	4011#	4011#
Weight.....	900#	935#	975#
Heaped Capacity.....	19.99 cu/ft.	21.69 cu/ft.	23.4 cu/ft
Cylinder Specifications			
Bore.....	2.50"	2.50"	2.50
Stroke.....	7.50"	7.50"	7.50
Rod Diameter.....	1.25"	1.25"	1.25
Specifications and design are subject to change without notice and without liability therefor.			



BOLT TORQUE

BOLT TORQUE SPECIFICATIONS

GENERAL TORQUE SPECIFICATION TABLE

Use the following torques when special torques are not given. These values apply to fasteners as received from suppliers, dry, or when lubricated with normal engine oil. They do not apply if special graphited or moly disulphide greases or other extreme pressure lubricants are used. This applies to both UNF and UNC threads. Remember to always use grade five or better when replacing bolts.

IMPORTANT: On all PLATED GRADE 8 bolts, reduce torque 15% from listed bolt torque specification.

SAE Grade No.		2				5				8*			
Bolt head identification marks as per grade. NOTE: Manufacturing Marks Will Vary													
		TORQUE		TORQUE		TORQUE		TORQUE		TORQUE		TORQUE	
Bolt Size		Pounds Feet		Newton-Meters		Pounds Feet		Newton-Meters		Pounds Feet		Newton-Meters	
Inches	Millimeters	Min.	Max.	Min.	Max.	Min.	Max.	Min.	Max.	Min.	Max.	Min.	Max.
1/4	6.35	5	6	7	8	9	11	12	15	12	15	16	20
5/16	7.94	10	12	14	16	17	20.5	23	28	24	29	33	39
3/8	9.53	20	23	27	31	35	42	48	57	45	54	61	73
7/16	11.11	30	35	41	47	54	64	73	87	70	84	95	114
1/2	12.70	45	52	61	70	80	96	109	130	110	132	149	179
9/16	14.29	65	75	88	102	110	132	149	179	160	192	217	260
5/8	15.88	95	105	129	142	150	180	203	244	220	264	298	358
3/4	19.05	150	185	203	251	270	324	366	439	380	456	515	618
7/8	22.23	160	200	217	271	400	480	542	651	600	720	814	976
1	25.40	250	300	339	406	580	696	787	944	900	1080	1220	1464
1-1/8	25.58	-	-	-	-	800	880	1085	1193	1280	1440	1736	1953
1-1/4	31.75	-	-	-	-	1120	1240	1519	1681	1820	2000	2468	2712
1-3/8	34.93	-	-	-	-	1460	1680	1980	2278	2380	2720	3227	3688
1-1/2	38.10	-	-	-	-	1940	2200	2631	2983	3160	3560	4285	4827

* Thick Nuts must be used with Grade 8 bolts

METRIC BOLT TORQUE SPECIFICATIONS

Size of Screw	Grade No.	Coarse Thread			Fine Thread		
		Ptich (mm)	Pounds Feet	Newton-Meters	Pitch (mm)	Pounds Feet	Newton-Meters
M6	5.6	1.0	3.6-5.8	4.9-7.9	-	-	-
	8.8		5.8-4	7.9-12.7		-	-
	10.9		7.2-10	9.8-13.6		-	-
M8	5.6	1.25	7.2-14	9.8-19	1.0	12-17	16.3-23
	8.8		17-22	23-29.8		19-27	25.7-36.6
	10.9		20-26	27.1-35.2		22-31	29.8-42
M10	5.6	1.5	20-25	27.1-33.9	1.25	20-29	27.1-39.3
	8.8		34-40	46.1-54.2		35-47	47.4-63.7
	10.9		38-46	51.5-62.3		40-52	54.2-70.5
M12	5.6	1.75	28-34	37.9-46.1	1.25	31-41	42-55.6
	8.8		51-59	69.1-79.9		56-68	75.9-92.1
	10.9		57-66	77.2-89.4		62-75	84-101.6
M14	5.6	2.0	49-56	66.4-75.9	1.5	52-64	70.5-86.7
	8.8		81-93	109.8-126		90-106	122-143.6
	10.9		96-109	130.1-147.7		107-124	145-168
M16	5.6	2.0	67-77	90.8-104.3	1.5	69-83	93.5-112.5
	8.8		116-130	157.2-176.2		120-138	162.6-187
	10.9		129-145	174.8-196.5		140-158	189.7-214.1
M18	5.6	2.0	88-100	119.2-136	1.5	100-117	136-158.5
	8.8		150-168	203.3-227.6		177-199	239.8-269.6
	10.9		175-194	237.1-262.9		202-231	273.7-313
M20	5.6	2.5	108-130	146.3-176.2	1.5	132-150	178.9-203.3
	8.8		186-205	252-277.8		206-242	279.1-327.9
	10.9		213-249	288.6-337.4		246-289	333.3-391.6

10360 6-8-95-2

LIMITED WARRANTY

All new Bradco products are warranted to be free from defects in materials or workmanship which may cause failure under normal usage and service when used for the purpose intended.

In the event of failure within twenty four (24) months from initial retail sale, lease or rental date (excluding cable, ground engaging parts such as sprockets, digging chain, bearings, teeth, tamping and demolition heads, blade cutting edges, pilot bits, auger teeth, auger heads & broom bristles), if after examination, Bradco determines failure was due to defective material and/or workmanship, parts will be repaired or replaced. Bradco may request defective part or parts be returned prepaid to them for inspection at their place of business at Delhi, Iowa, or to a location specified by Bradco.

Any claims under this warranty must be made within fifteen (15) days after the Buyer learns of the facts upon which such claim is based. All claims not made in writing and received by Bradco within the time period specified above shall be deemed waived.

THIS WARRANTY IS IN LIEU OF ALL OTHER WARRANTIES EXPRESSED OR IMPLIED AND THERE ARE NO WARRANTIES OF MERCHANTABILITY OR OF FITNESS FOR A PARTICULAR PURPOSE. IN NO EVENT SHALL BRADCO BE LIABLE FOR CONSEQUENTIAL OR SPECIAL DAMAGE.

BRADCO'S LIABILITY FOR ANY AND ALL LOSSES AND DAMAGES TO BUYER, RESULTING FROM ANY CAUSE WHATSOEVER, INCLUDING BRADCO'S NEGLIGENCE, IRRESPECTIVE OF WHETHER SUCH DEFECTS ARE DISCOVERABLE OR LATENT, SHALL IN NO EVENT EXCEED THE PURCHASE PRICE OF THE PARTICULAR PRODUCTS WITH RESPECT TO WHICH LOSSES OR DAMAGES ARE CLAIMED, OR, AT THE ELECTION OF BRADCO, THE REPAIR OR REPLACEMENT OF DEFECTIVE OR DAMAGED PRODUCTS.

4-IN-1 MULTI-PURPOSE BUCKETS

72", 78" & 84" CONSTRUCTION BUCKETS

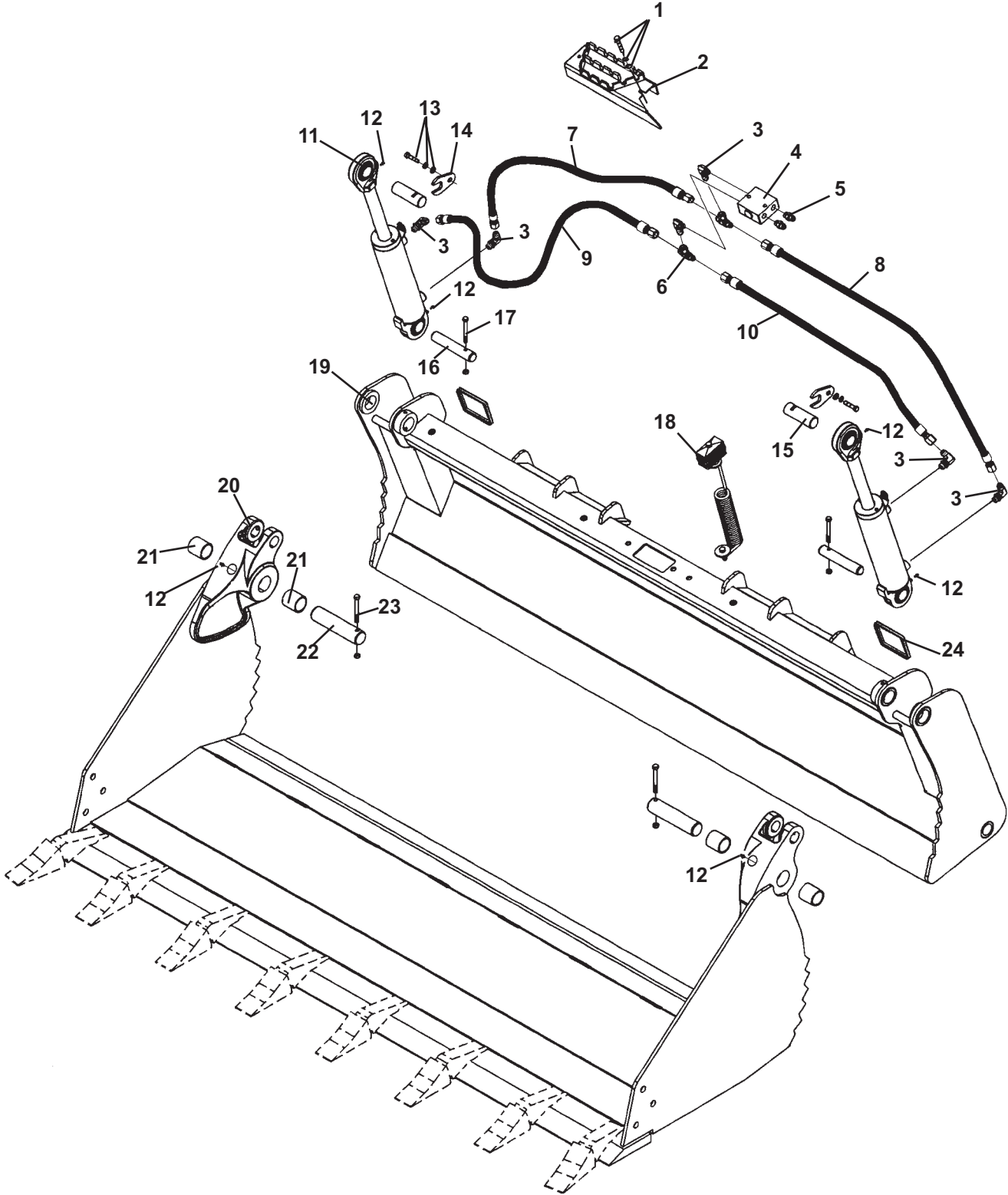

4-IN-1 MULTI-PURPOSE BUCKETS

72", 78" & 84" CONSTRUCTION BUCKETS

<u>ITEM</u>	<u>REQ'D</u>	<u>PART NO.</u>	<u>DESCRIPTION</u>
1	3	1027	.31" UNC X 2.25" Hex Capscrew
	3	1502	.31" Lock Washer
	3	1513	.31" Flat Washer
2	1	107757	Hydraulic Cover
3	6	3434	90° Elbow 6MBo-6MJ
4	1	88536	Hydraulic Valve
5	2	3457	Straight Connector 6MBo-6MJ
6	2	30031	Tee 6MJ-6MJ-6FJX
7	1	35806	Hose .25" X 45" 6JFX-6FJX (72" Bucket Assembly)
	1	37263	Hose .25" X 48" 6JFX-6FJX (78" Bucket Assembly)
	1	37579	Hose .25" X 51" 6JFX-6FJX (84" Bucket Assembly)
8	1	38324	Hose .25" X 44" 6JFX-6FJX (72" Bucket Assembly)
	1	38278	Hose .25" X 46" 6JFX-6FJX (78" Bucket Assembly)
	1	35807	Hose .25" X 50" 6JFX-6FJX (84" Bucket Assembly)
9	1	38156	Hose .25" X 38" 6JFX-6FJX (72" Bucket Assembly)
	1	37917	Hose .25" X 41" 6JFX-6FJX (78" Bucket Assembly)
	1	38324	Hose .25" X 44" 6JFX-6FJX (84" Bucket Assembly)
10	1	35695	Hose .25" X 36" 6JFX-6FJX (72" Bucket Assembly)
	1	37916	Hose .25" X 40" 6JFX-6FJX (78" Bucket Assembly)
	1	37264	Hose .25" X 43" 6JFX-6FJX (84" Bucket Assembly)
11	2	107540	Cylinder Assembly
12	6	6616	Grease Fitting
13	2	1023	.31" UNC X 1.25" Hex Capscrew
	2	1502	.31" Lock Washer
	2	1513	.31" Flat Washer
14	2	107961	Pin Lock
15	2	108996	Cylinder Pin
16	2	107552	Cylinder Pin
17	2	1029	.31" UNC X 2.75" Hex Capscrew
	2	1753	.31" UNC Nylock Nut
18	1	103177	Hose Clamp Assembly
19	1	108279	72" Back Blade
	1	108253	78" Back Blade
	1	107828	84" Back Blade
20	1	108286	72" Clam
	1	107982	72" Clam with Teeth
	1	108267	78" Clam
	1	107984	78" Clam with Teeth
	1	107836	84" Clam
	1	107986	84" Clam with Teeth
21	4	14550	Bushing
22	2	107551	Pivot Pin
23	2	1030	.31" UNC X 3.00" Hex Capscrew
	2	1753	.31" UNC Nylock Nut
24	24"	34020	Rubber Edging

HYDRAULIC ASSEMBLIES

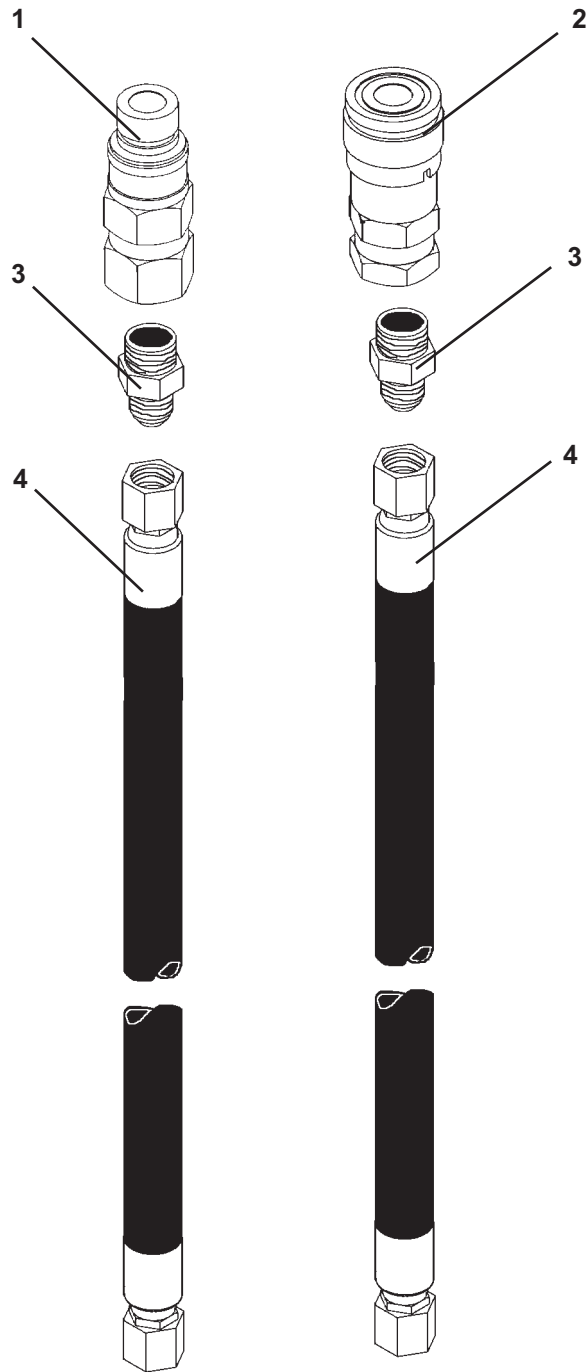

HYDRAULIC ASSEMBLIES

HYDRAULIC ASSEMBLY #103577

<u>ITEM</u>	<u>REQ'D</u>	<u>PART NO.</u>	<u>DESCRIPTION</u>
1	1	19632	Male Coupler 12FBo .50" Body
2	1	22518	Female Coupler 12FBo .50" Body
3	2	30201	Straight Connector 12MBo-6MJ
4	2	37750	Hose .25" x 66" 6FJX-6FJX

HYDRAULIC ASSEMBLY #103603

<u>ITEM</u>	<u>REQ'D</u>	<u>PART NO.</u>	<u>DESCRIPTION</u>
1	1	19632	Male Coupler 12FBo .50" Body
2	1	22518	Female Coupler 12FBo .50" Body
3	2	30201	Straight Connector 12MBo-6MJ
4	2	38327	Hose .25" x 94" 6FJX-6FJX

CYLINDER ASSEMBLY

ASSEMBLY #107540

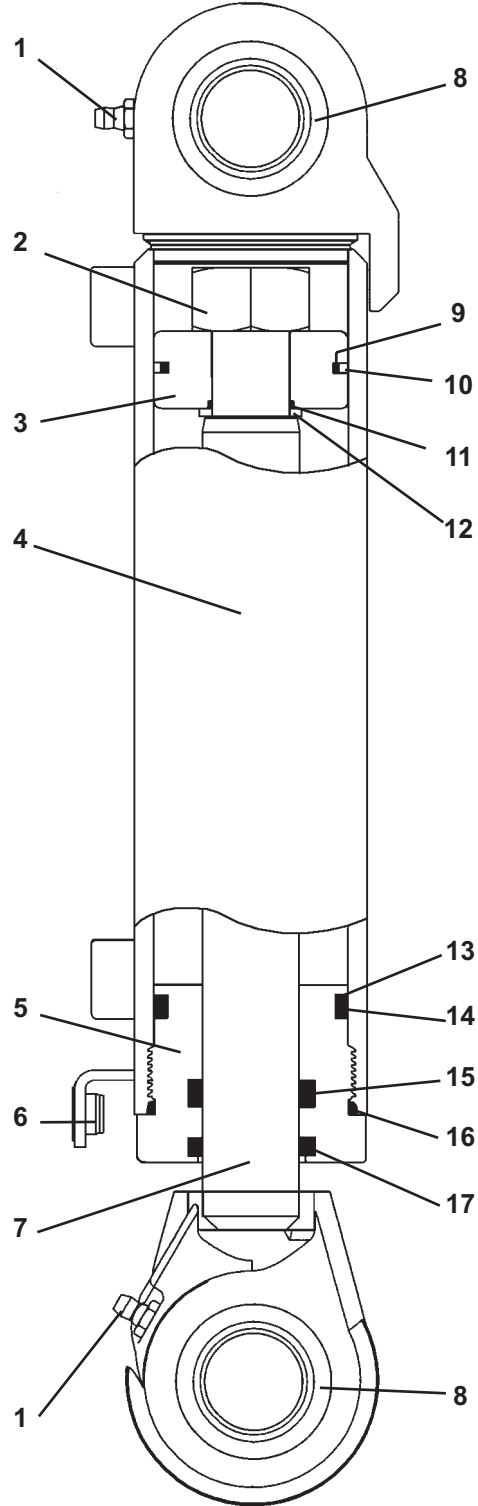

CYLINDER ASSEMBLY

ASSEMBLY #107540

<u>ITEM</u>	<u>REQ'D</u>	<u>PART NO.</u>	<u>DESCRIPTION</u>
1	2	6616	Grease Fitting
2	1	1483	Hex Nut (Torque to 150-200 ft. lbs.)
3	1	50252	Piston
4	1	107538	Cylinder Tube
5	1	77458	Cylinder Gland
6	1	10140	Rivet Nut
7	1	107539	Cylinder Rod
8	2	62523	Self-Aligning Bushing
9	1	4645*	O'Ring
10	1	4644*	Piston Ring
11	1	4641*	O'Ring
12	1	5421	Washer
13	1	4609*	O'Ring
14	1	4610*	Back-Up Washer
15	1	45219*	Poly-Pak Seal
16	1	45250*	O'Ring
17	1	45389*	Rod Wiper

NOTE: Seal Kit #45617 includes all parts marked with an asterisk (*). Part are not sold separately.

10930 4-6-07

OPTIONS

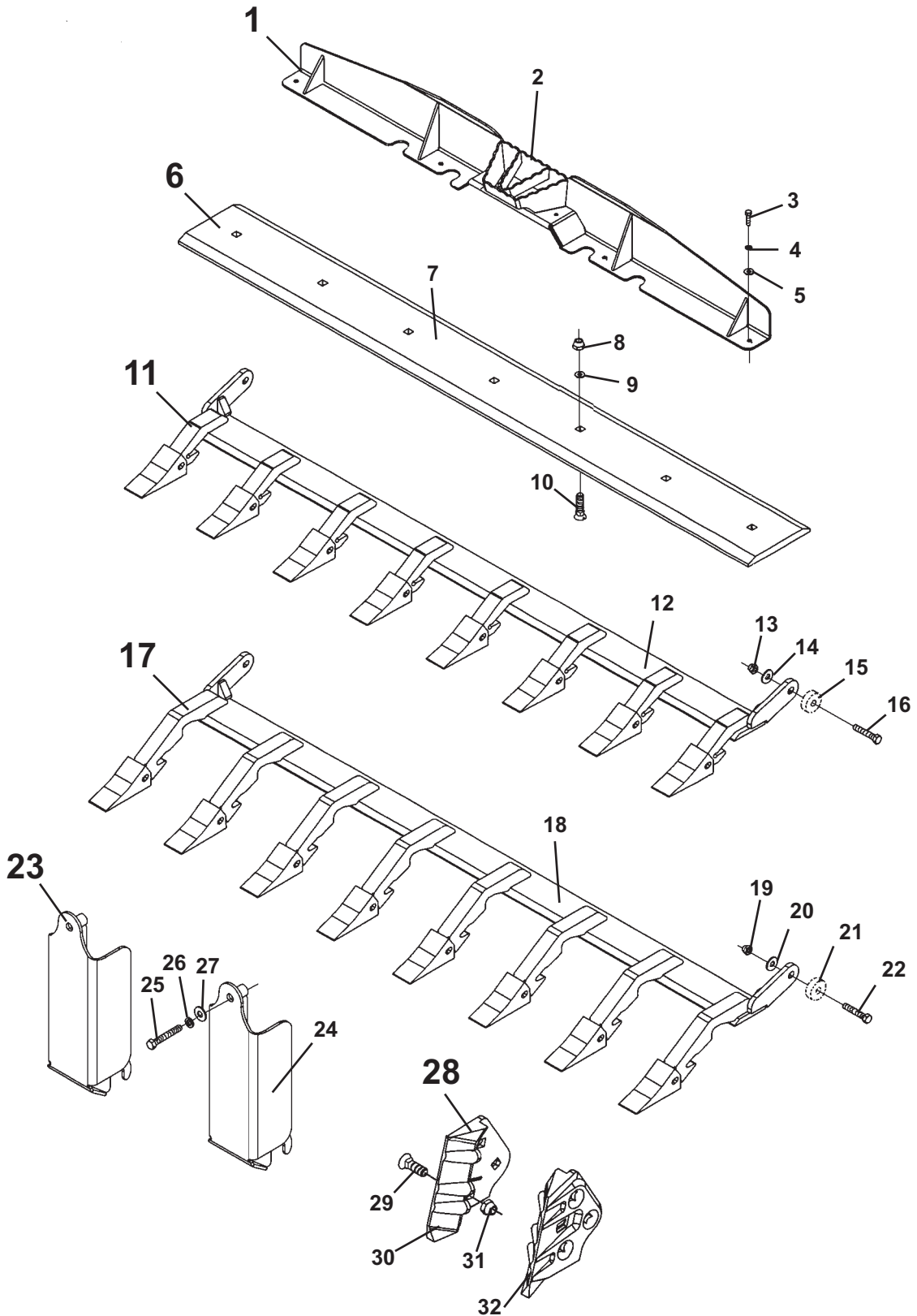

OPTIONS

<u>ITEM</u>	<u>REQ'D</u>	<u>PART NO.</u>	<u>DESCRIPTION</u>
1	-	107530	72" Spill Guard Assembly
		108880	78" Spill Guard Assembly
		108883	84" Spill Guard Assembly
2	1	107531	72" Spill Guard
	1	108881	78" Spill Guard
	1	18884	84" Spill Guard
3	4	1022	.31" UNC X 1.00" Hex Capscrew
4	4	1502	.31" Lock Washer
5	4	1513	.31" Flat Washer
6	-	15028	72" Bolt-On Cutting Edge Assembly
		16204	78" Bolt-On Cutting Edge Assembly
		16183	84" Bolt-On Cutting Edge Assembly
7	1	15097	72" Cutting Edge
	1	16219	78" Cutting Edge
	1	16182	84" Cutting Edge
8	7 or 9	1839	.62" UNC Deformed Lock Nut
9	7 or 9	1627	.62" Hard Flat Washer
10	7	10021	.62" UNC X 2.50" Plow Bolt - Grade 8 (72" Clam)
	9	10020	.62" UNC X 2.75" Plow Bolt - Grade 8 (78" & 84" Clam)
11	-	33823	72" Bolt On Toothbar Assembly - Without Bolt-On Cutting Edge
		16288	78" Bolt On Toothbar Assembly - Without Bolt-On Cutting Edge
		16193	84" Bolt On Toothbar Assembly - Without Bolt-On Cutting Edge
12	1	15527	72" Toothbar
	1	16511	78" Toothbar
	1	16513	84" Toothbar
13	2	1841	.50" UNC Deformed Lock Nut
14	2	1646	.50" Hard Flat Washer
15	2	19019	Spacer (If needed)
16	2	1781	.50" UNC X 2.00" Hex Capscrew - Grade 8
	2	1818	.50" UNC X 2.75" Hex Capscrew - Grade 8 (Use with Spacer)
17	-	16988	72" Bolt On Toothbar Assembly - With Bolt-On Cutting Edge
		16989	78" Bolt On Toothbar Assembly - With Bolt-On Cutting Edge
		16991	84" Bolt On Toothbar Assembly - With Bolt-On Cutting Edge
18	1	18503	72" Toothbar
		18504	78" Toothbar
		18506	84" Toothbar
19	2	1841	.50" UNC Deformed Lock Nut
20	2	1646	.50" Hard Flat Washer
21	2	19019	Spacer (If needed)
22	2	1781	.50" UNC X 2.00" Hex Capscrew - Grade 8
	2	1818	.50" UNC X 2.75" Hex Capscrew - Grade 8 (Use with Spacer)
23	-	107785	Cylinder Guard Assembly
24	2	107525	Cylinder Cover
25	2	1048	.38" UNC X 2.25" Hex Capscrew
26	2	1503	.38" Lock Washer
27	2	1525	.38" Flat Washer
28	-	107786	Side Cutter Assembly - Bolt-On
29	6	102717	.62" UNC X 1.75" Plow Bolt
30	1	106763	Right Side Cutter
31	6	1839	.62" UNC Deformed Lock Nut
32	1	106762	Left Side Cutter

10932 4-6-07